

## Operating Instructions and Spare Parts List

# ZR Monocyclone

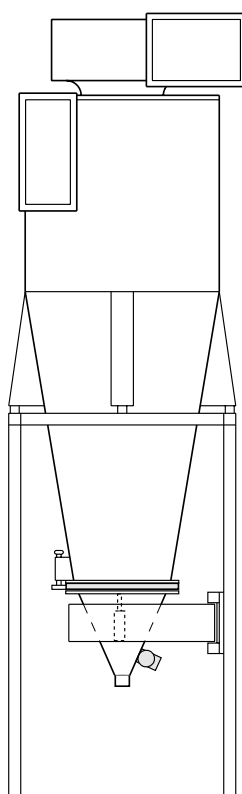



# Table of Contents

<b>1. General description of the system</b> .....	<b>1</b>
1.1 Introduction .....	1
1.2 Technical data .....	2
<b>2. Requirements on the operator</b> .....	<b>3</b>
2.1 Power supply .....	3
2.1.1 Compressed air connections .....	3
2.1.2 Signal ground .....	3
2.2 Safety precautions .....	3
2.3 Admissible environmental influences .....	3
<b>3. Operation</b> .....	<b>4</b>
3.1 Description of Function .....	4
3.2 Colour change with recovery .....	5
<b>4. Maintenance and maintenance</b> .....	<b>6</b>
4.1 Cleaning and check .....	6
<b>5. Spare parts</b> .....	<b>7</b>



## **1. GENERAL DESCRIPTION OF THE SYSTEM**

### **1.1 INTRODUCTION**

The Monocyclone (hereafter called the cyclone) serves for processing and recovering easy flowing, non-sticking types of powder.

Its special area of application is the processing of coating powder in multiple colour operation.

Any colour can be coated and recovered because of the simple cleaning of the cyclone. The recovered powder is transported by a powder recovery system (hereafter called the Dense Phase Conveyor) to the electrostatic powder coating gun.

The powder which has not been separated is usually passed on to an After Filter.

## 1.2 TECHNICAL DATA

Type of cyclone	ZR960G	ZR1150G	ZR1300G	ZR1400G	ZR1500G
External dimensions (mm):					
L =	1190	1454	1520	1720	1720
B =	1190	1454	1520	1720	1720
H =	4163	4763	5249	5694	6000
Suction power (m <sup>3</sup> /h):	8000	10000	14000	17000	21000
Max. suction power (m <sup>3</sup> /h):	9000	13000	16000	20000	24000
Total weight without Dense Phase Conveyor (kg):	510	615	695	750	805
Compressed air connection:	max. 4 bar				
Max. water vapour content:	1.3 g/m <sup>3</sup>				
Max. oil vapour content:	0.1 mg/kg				
Colour:	RAL 7032 Structure (flint grey)				
Electrical external vibrator:					
Voltage:	230/400 V				
Frequency:	50 Hz				
Motor performance:	0.18 kW				
Imbalance:	0-100 kp				
Consumption of air for the Dense Phase Conveyor:	Approximately 20 nm <sup>3</sup> /h (with easy flowing coating powder of standard quality)				
Sieve mesh on the Sieve machine:	400 μ				

## **2. REQUIREMENTS ON THE OPERATOR WHICH CAN BE ENSURED AT THE PLACE OF ASSEMBLY,**

### **2.1 POWER SUPPLIES**

#### **2.1.1 Compressed air connections**

Powder and oil-free (oil content - 0.1 mg/kg) pre-regulated to approx. 8 bar.  
Max. residual water content of 1.3 g/m<sup>3</sup>.

**2.1.2 Signal ground:** According to local regulations

### **2.2 SAFETY PRECAUTIONS**

The following regulations are to be observed by the operator of a cyclone:

- ZH 1/444 - Instruction sheet for electrostatic powder coating.
- ZH 1/200 - Guidelines for the avoidance of danger of ignition due to electrostatic charging.
- VDMA 24371 (Parts 1 + 2) VDMA standard forms - Surface technology
- DIN 57147/VDI 0147 (Parts 1 + 2) - Setting up of stationary electrostatic spraying equipment.
- VDI 3673 - Pressure relief of powder explosions.
- VDI2263 - Prevention of powder explosions and powder fires.

### **2.3 ADMISSIBLE ENVIRONMENTAL INFLUENCES**

- The ambient temperature must not exceed 30° Celsius
- When using low melting point powders a still lower ambient temperature may be necessary.
- The maximum relative humidity is approximately 75 %.

### **3. OPERATION**

#### **3.1 DESCRIPTION OF FUNCTION**

The air flow necessary for powder recovery is usually produced by the After Filter. Powder laden air is sucked into the cyclone, then the usable powder is separated from the air current.

The recovered powder falls to the bottom of the cone onto a high-grade steel sieve with a mesh size of 400  $\mu$ .

The unusable powder is usually fed to an After Filter.

The sieving equipment is attached to the collecting funnel and clamped to the funnel flange of the cyclone by pneumatic cylinders.

The collecting funnel, with the cleaned powder, can be completely swivelled out for cleaning purposes at a colour change, after disengaging from the sieve machine under the cyclone. The powder recovery system is underneath the collecting funnel. The recovered powder can be transported further (e.g. to the fluidizing container, powder coating equipment) by means of a Dense Phase Conveyor.

The powder cycle is thus closed.

The remaining content of the pre-cleaned air must be separated in the After Filter.



### 3.2 COLOUR CHANGE WITH RECOVERY

1. Suction on
2. Set the selector switch of the Dense Phase Conveyor to Clean.
3. Remove the powder hose between the fluid container and cyclone on the fluid container, and blow out towards the cyclone.
4. Operate the clamp lever
5. Swing out the sieve, clean with a vacuum cleaner and blow out with compressed air.
6. Swivel the collecting funnel 60 % under cyclone, blow out with compressed air.  
The loosened powder is thereby sucked into the cyclone by the air current and is fed to the After Filter.
7. Blow out the cyclone conscientiously with the compressed air lance. Blow off the upper section of the cyclone, particularly the outside the immersion tube.
8. Switch off the suction.
9. Swivel the Sieve machine in up to the stop and operate the clamp lever.
10. Put the injectors into the fluidizing container, filled with new powder.
11. Make sure that all connections are properly connected.
12. The system is ready for operation.

 **CAUTION**

For contrast colour changes it is recommended to operate for the first 5 minutes with the flanged collecting funnel open and the Dense Phase Conveyor switched off, so that the cyclone cleans itself with the new colour.

## 4. MAINTENANCE

### 4.1 CLEANING AND CHECK

With careful operation the cyclone is almost maintenance-free.  
For maintenance the following points are to be observed:

<b>Designation</b>	<b>Cleaning or check cycle</b>	<b>Remarks</b>
Collecting funnel - inside	Daily	Blow out with compressed air. Sintering can occur with some powder types. These are to be removed with suitable cleaning agents.
Cyclone cone - inside	Daily	Blow out with compressed air. Sintering can occur with some powder types. These are to be removed with suitable cleaning agents.
Cyclone - outside	Monthly	Vacuum the powder deposits from outside. Avoid powder depositing

 **CAUTION**

All contacts and screws in the switch cabinet are to be checked quarterly for tightness by the house electrician!

**5. SPARE PARTS AND WEAR PARTS**

Pos.	Qty	Designation	Order no.
1	1	External electric vibrator	on request
2	1	High-grade steel sieve - 400 $\mu$ mesh	on request*
3	1	Tension ring - inside - $\varnothing$ 25 mm	on request
4	lin.m.	Cell rubber seal - 8 x 30 mm	on request**
5	lin.m.	Cell rubber seal - 15 x 30 mm	on request**
6	3	Short-stroke cylinder with reed contact	on request
8	4	Metal/rubber buffer - $\varnothing$ 75 mm	on request
9	1	Grounding on the After Filter (Spring steel 17501.100.650)	on request
10	1	Cleaning lance	on request

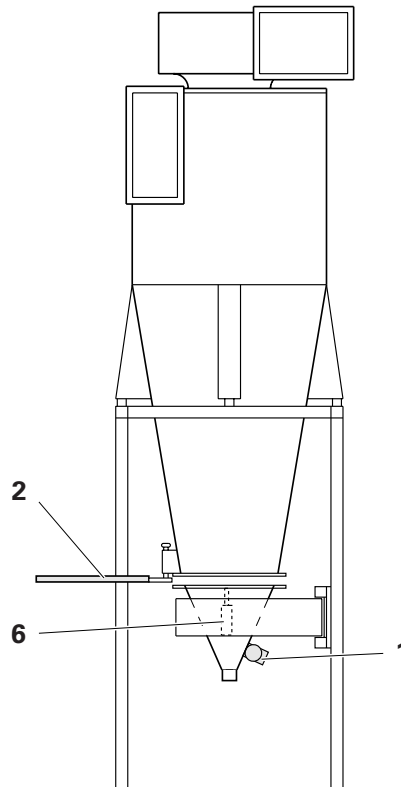

#Please indicate length required.

\*Wear parts

**NOTES:**