

Reciprocator (ZA13)

Smooth running characteristics for perfect coating results

Short or long stroke operation - the ZA reciprocator offers simple programming, smooth running and high loading capacity.

Customer benefits:

- Long-stroke and short-stroke operation
- High loading capacity up to 100 kg
- Loading capacity for max. 6 gun axes UA04
- Slim column design allows space-saving arrangement of the guns
- Extremely smooth running through toothed belt transmission
- Maintenance-free AC motor
- Free axis programming via MagicControl CMxx
- Storable programs
- Bus-/CAN-Bus technology integrated into the control unit



ZA13 with five gun axes UA04

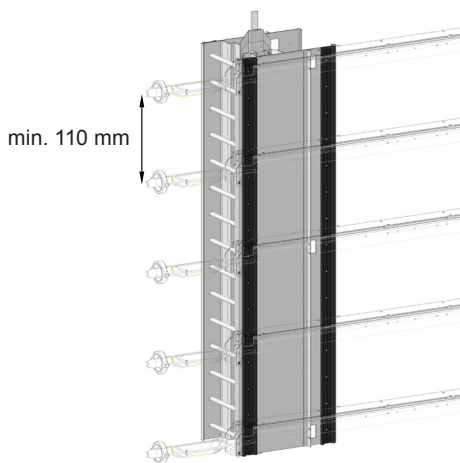
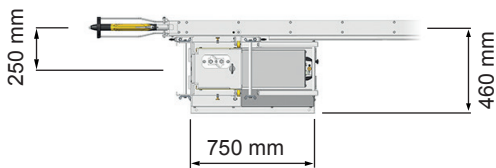
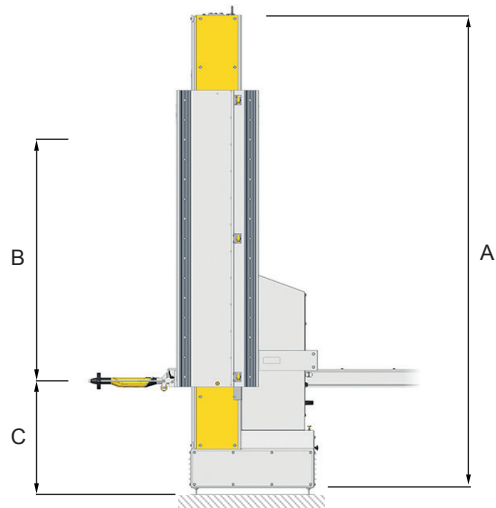

Expansion kit

Technical data

Stroke speed	0,08 - 0,4 m/s
Acceleration	0,1 - 1,5 m/s ²
Loading capacity	max. 100 kg
Positioning system	Incremental encoder
Voltage	230 V, 50/60 Hz
Temperature range	10 °C - +40 °C
Zone definition	⊕ II 3 D (ATEX Zone 22)
Motor type	Three-phase asynchronous motor
Power	0,75 kW

Reciprocator ZA	13	18	23	28
Total height (A)	2.385 mm	2.885 mm	3.385 mm	3.885 mm
Adjustable stroke (B) (excl. expansion kit)	1.300 mm	1.800 mm	2.300 mm	2.800 mm
Lower inflection point (C)	700 mm	700 mm	700 mm	700 mm

Associated system components

- Gun axis UA04 (vertical distance mechanically adjustable, minimum distance = 110 mm)
- Automatic gun OptiGun GA03-X
- MagicControl CMxx

Gema Switzerland reserves the right to make technical changes without prior notice!

Gema Switzerland GmbH

Mövenstrasse 17 | 9015 St.Gallen | Switzerland
 T +41 71 313 83 00 | F +41 71 313 83 83
 www.gemapowdercoating.com

