

Gun axis UA05

Gun axis for compact gun spacing and optimized penetration during coating

The gun axis UA05 is used for the horizontal positioning of the automatic guns during the coating of complex components. In combination with the vertical reciprocator ZA16, the UA05 unfolds its full strength to solve complex application tasks.

The UA05 can be mounted on a vertical axis with a separation of 110 mm. This spacing reduces the distance between the coating zones, maximizing the effectiveness of the individual axis coverage into many recess areas. The rapid UA05 axis movement with minimum reaction time optimizes penetration and exposure time of the gun to the work piece.

The latest drive technology with servo motors and toothed belt transmission pinpoint the feed motion of the automatic guns to the optimum application position.

A cleaning function (blow-off ring) removes powder from the guns and support tube during line gaps and during color change.

Main Features:

- Compact, slim design with 110 mm vertical gun spacing
- Maintenance-free servo motor – drive technology
- Smooth operation with toothed belt transmission
- Precision point accuracy of the feed movement
- Robust, dirt-resistant and easily accessible components
- Integrated cleaning function (blow-off ring) for gun body and support tube during line gaps and color change
- Fast response; up to 0.6 m/s stroke speed over 1.85 m stroke length travel for coating of large work pieces
- Single axis or 3D programming via MagicControl 4.0

Customer benefits:

- Designed for complex application demands and difficult part geometries without the need for robots or individual programs.
- The compact design allows high density mounting with 110 mm vertical gap between the automatic guns. This enables penetration into minimal recess areas and automatic coating of even the most complex geometries.
- Rapid UA05 axis movement with minimum reaction time, optimizing penetration and exposure time of the gun to the work piece in recess areas.
- In conjunction with MagicControl and 3D programming, UA05 enables precision placement of the gun tip to the product. When used in combination with Dynamic Contour Detection placement of individual guns over the vertical array is precisely directed according to specific product geometries.

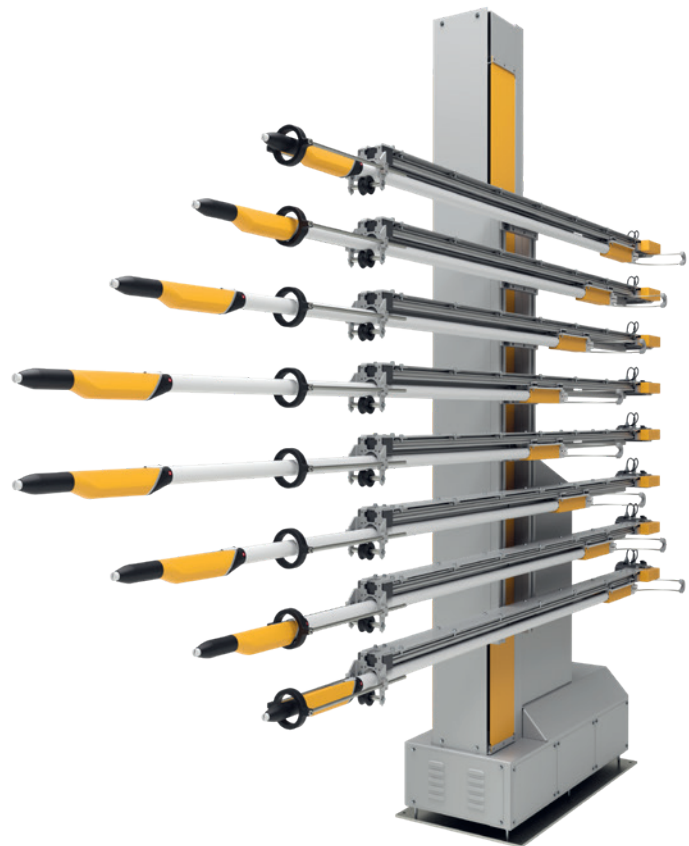

UA05 gun axes mounted on ZA16

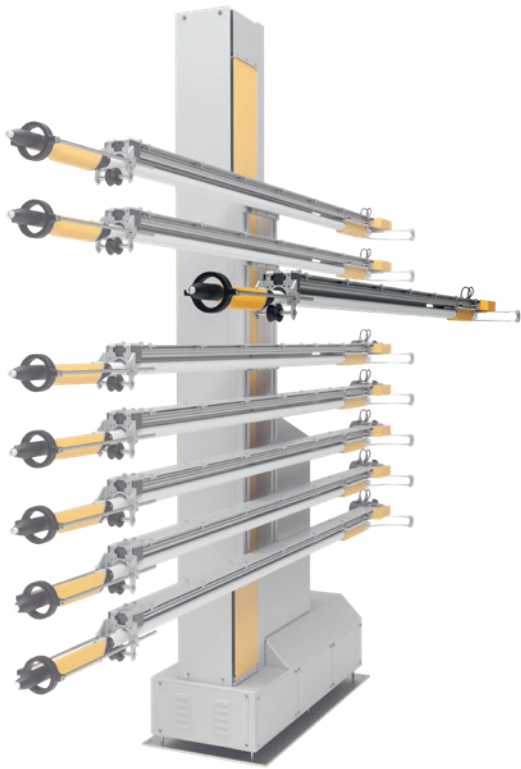

Technical data UA05

Stroke speed	0.08 - 0.6 m/s
Acceleration	0.1 - 2.0 m/s ²
Loading capacity	Automatic gun GA03-X
Voltage	230 V, 50/60 Hz
Weight Gun axis UA05 (stroke 1.85 m)	16 kg (incl. gun and powder hose)
Temperature range	10 °C to +40 °C
Compressed air (cleaning function)	6-8 bar / 87-116 psi
Synchronous motor	400 watt degree of protection IP 54, insulation class F
Position detection	Pulse generator extension integrated in synchronous motor

Gun axis UA05	
Min. vertical gap [A]	110 mm, mechanically adjustable
Adjustable stroke* [B]	max. 1.85 m

* customised stroke length available

Associated system components

- Vertical reciprocator:
ZA16 (max. 8 gun axes UA05)
ZA07 (max. 2 gun axes UA05)
- Automatic gun OptiGun GA03-X
- MagicControl 4.0 system control

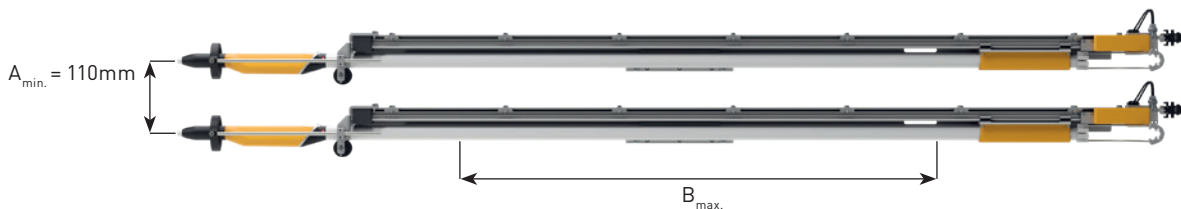

Gema Switzerland reserves the right to make technical changes without prior notice!

Gema Switzerland GmbH

Mövenstrasse 17 | 9015 St.Gallen | Switzerland
T +41 71 313 83 00 | F +41 71 313 83 83
www.gemapowdercoating.com

