

Reciprocator (ZA16)

Vertical axis for complex application tasks

ZA16 is the powerful robust reciprocator providing a high load capacity in a space-saving design, precision movement and ease of programming. The reciprocator is designed for users who want to increase productivity or reduce manual reinforcement through improved automation while coating parts with complex geometries. ZA16 is used for Dynamic Contour Detection applications in combination with UA05 gun axes and the system control MagicControl 4.0.

Main Features:

- Loading capacity for max. 8 gun axes UA05 (= 130 kg)
- Vertical gap between automatic guns 110 mm
- Long-stroke and short-stroke operation
- Extremely smooth running through toothed belt transmission

Customer benefits:

- Designed for complex application demands and difficult part geometries
- Slim column design allows space-saving arrangement of the guns
- 110 mm vertical gun spacing reduces the distance between the coating zones, maximizing the effectiveness of the individual axis coverage into recess areas
- Bus-/CAN-Bus technology integrated into the control unit for performance feedback and monitoring
- Simple graphic display on the MagicControl enables ease of adjustment and program storage

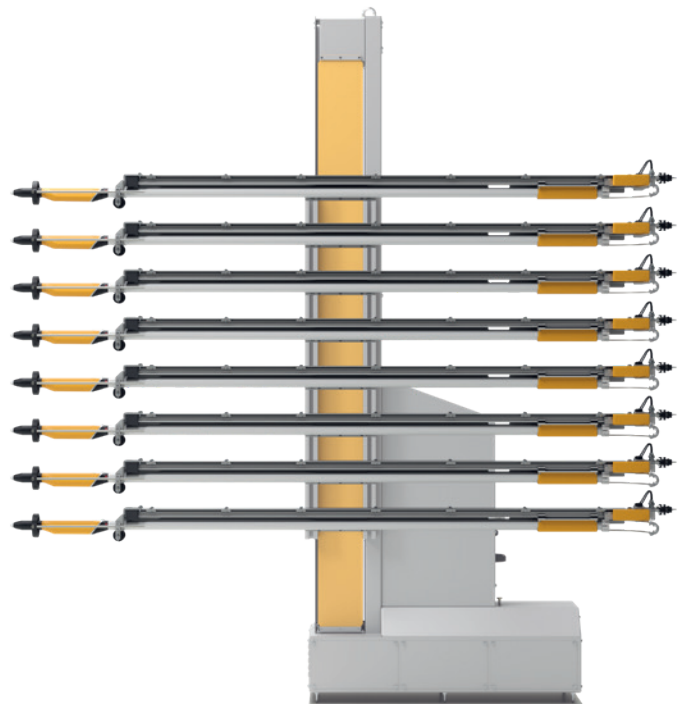

ZA16 with eight gun axes UA05

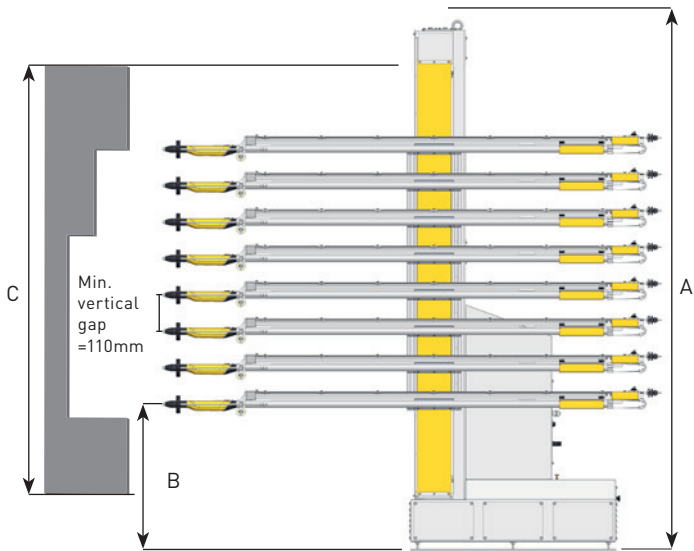

Technical data ZA16

Stroke speed	0.08 - 0.4 m/s
Acceleration	0.1 - 1.5 m/s ²
Loading capacity	max. 8 gun axes UA05 (= 130 kg)
Positioning system	Incremental encoder
Voltage	3 x 400 V; 50/60 Hz
Temperature range	10 °C to +40 °C
ATEX Zone	⊕ II 3 D (ATEX Zone 22)
Motor type	Three-phase asynchronous motor
Power	1.5 kW

Reciprocator ZA16	13	18	23	28	33
Total height (A)	2.385 m	2.885 m	3.385 m	3.885 m	4.385 m
Lower turnpoint (B)	0.45 m	0.45 m	0.45 m	0.45 m	0.45 m
Max. object height (incl. strokes) (C)	1.795 m	2.295 m	2.795 m	3.295 m	3.795 m

Mounting options

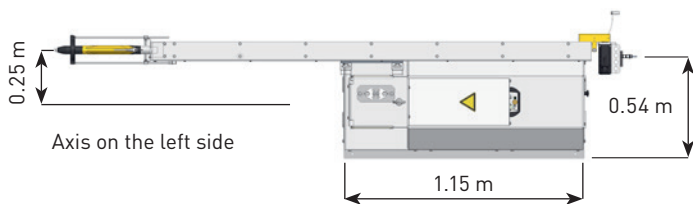

Axis on the left side

Axis on the right side

Axis on both sides

Associated system components

- Gun axis UA05:
Min. vertical gap: 110 mm, mechanically adjustable
- Automatic gun OptiGun GA03-X
- MagicControl 4.0 system control

009702-EN-08-2021

Gema Switzerland reserves the right to make technical changes without prior notice!

Gema Switzerland GmbH

Mövenstrasse 17 | 9015 St.Gallen | Switzerland
T +41 71 313 83 00 | F +41 71 313 83 83
www.gemapowdercoating.com

