

Operating instructions and spare parts list

PH300

Fresh powder hopper

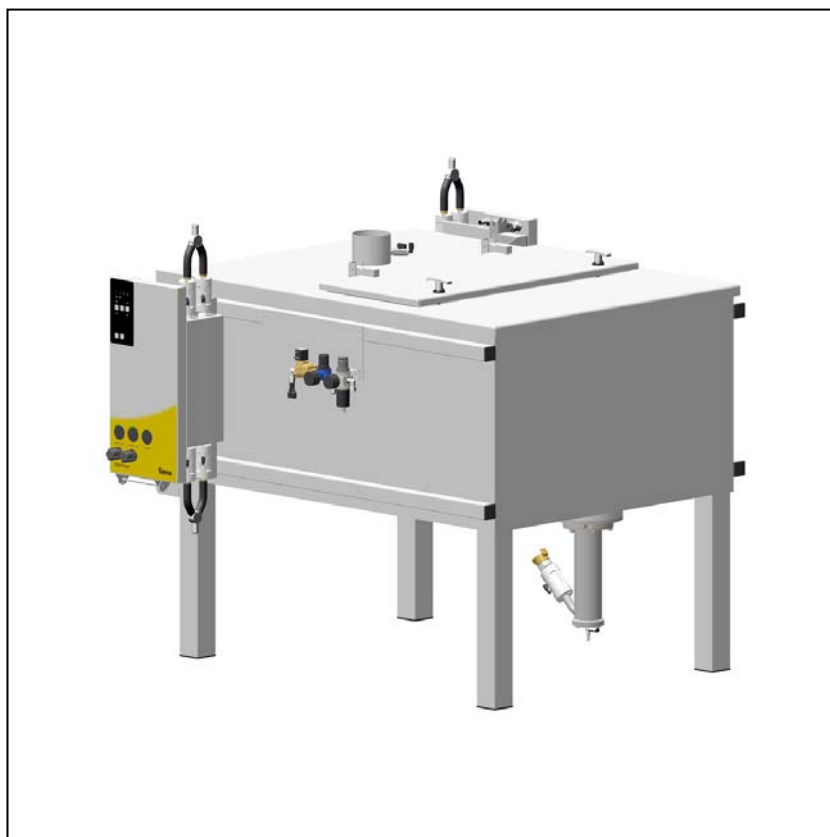

Translation of the original operating instructions

Documentation – PH300

© Copyright 2008 Gema Switzerland GmbH

All rights reserved.

This publication is protected by copyright. Unauthorized copying is prohibited by law. No part of this publication may be reproduced, photocopied, translated, stored on a retrieval system or transmitted in any form or by any means for any purpose, neither as a whole nor partially, without the express written consent of Gema Switzerland GmbH.

MagicCompact, MagicCylinder, MagicPlus, MagicControl, OptiFlex, OptiControl, OptiGun, OptiSelect, OptiStar and SuperCorona are registered trademarks of Gema Switzerland GmbH.

OptiFlow, OptiCenter, OptiMove, OptiSpeeder, OptiFeed, OptiSpray, OptiSieve, OptiAir, OptiPlus, OptiMaster, MultiTronic, EquiFlow, Precise Charge Control (PCC), Smart Inline Technology (SIT) and Digital Valve Control (DVC) are trademarks of Gema Switzerland GmbH.

All other product names are trademarks or registered trademarks of their respective holders.

Reference is made in this manual to different trademarks or registered trademarks. Such references do not mean that the manufacturers concerned approve of or are bound in any form by this manual. We have endeavored to retain the preferred spelling of the trademarks, and registered trademarks of the copyright holders.

To the best of our knowledge and belief, the information contained in this publication was correct and valid on the date of publication. Gema Switzerland GmbH makes no representations or warranties with respect to the contents or use of this publication, and reserves the right to revise this publication and make changes to its content without prior notice.

For the latest information about Gema products, visit www.gemapowdercoating.com.

For patent information, see www.gemapowdercoating.com/patents or www.gemapowdercoating.us/patents.

Printed in Switzerland

Gema Switzerland GmbH
Mövenstrasse 17
9015 St.Gallen
Switzerland

Phone: +41-71-313 83 00

Fax.: +41-71-313 83 83

E-Mail: info@gema.eu.com

Table of contents

General safety regulations	3
Safety symbols (pictograms).....	3
Proper use.....	3
Product specific security regulations	4
General information	4
Installation	5
Grounding	5
Repairs.....	5
About this manual	7
General information	7
Product description	9
Field of application	9
Utilization.....	9
Reasonably foreseeable misuse.....	9
Technical data.....	10
Powder transport.....	10
Electrical data	10
Pneumatic data	10
Dimensions	10
Processible powders.....	10
Sound pressure level	11
Rating plate.....	11
Design and function	13
General view	13
Compressed air indicators	14
Feed Control Hood.....	15
Principle of function.....	16
Commissioning	17
Set-up and assembly	17
Preparation for start-up	17
Compressed air supply	17
Grounding of the fresh powder hopper	18
Coating operation	19
Before switching on.....	19
Start up with the single control.....	19
Start up with the main control	20
Cleaning	21
Setting values	23
Compressed air.....	23

Fault localization	25
General information	25
Maintenance	27
Monitoring during operation.....	27
Daily maintenance	27
Additional monthly maintenance work.....	27
Decommissioning, storage	29
Introduction	29
Safety rules.....	29
Requirements on personnel carrying out the work.....	29
Storage conditions	29
Storage duration	29
Space requirements	29
Physical requirements	29
Hazard notes	30
Shut-down.....	30
Decommissioning	30
Cleaning.....	30
Disassembly/attachment of transport safety devices	30
Packing	30
Identification	30
Maintenance during storage	30
Maintenance schedule.....	30
Maintenance works.....	30
Return to service	30
Commissioning following storage.....	30
Packing, transport	31
Introduction	31
Safety rules.....	31
Requirements on personnel carrying out the work.....	31
Packing material	31
Transport	31
Data concerning goods to be transported	31
Mode of transportation.....	32
Loading, transferring the load, unloading	32
Spare parts list	33
Ordering spare parts.....	33
PH300 Fresh powder hopper	34
Pneumatic unit – PH300.....	35
Fluidized hopper – PH300	36

General safety regulations

This chapter sets out the fundamental safety regulations that must be followed by the user and third parties using the PH300.

These safety regulations must be read and understood before the PH300 is put into operation.

Safety symbols (pictograms)

The following warnings with their meanings can be found in the Gema Switzerland operating instructions. The general safety precautions must also be followed as well as the regulations in the operating instructions.

**DANGER!**

Danger due to electrically live or moving parts. Possible consequences: death or serious injury

**WARNING!**

Improper use of the equipment could damage the machine or cause it to malfunction. Possible consequences: minor injuries or damage to equipment

**INFORMATION!**



Useful tips and other information

Proper use

1. The PH300 is built to the latest specification and conforms to the recognized technical safety regulations and is designed for the normal application of powder coating.
2. Any other use is considered non-compliant. The manufacturer shall not be liable for damage resulting from such use; the user bears sole responsibility for such actions. Gema Switzerland GmbH must be consulted prior to any use of the PH300 for any purposes or substances other than those indicated in our guidelines.
3. Observance of the operating, service and maintenance instructions specified by the manufacturer is also part of conformity of use. The PH300 should only be used, maintained

and started up by trained personnel, who are informed about and are familiar with the possible hazards involved.

4. Start-up (i.e. the execution of intended operational tasks) is forbidden until it has been established that the PH300 has been set up and wired according to the guidelines for machinery (2006/42 EC). EN 60204-1 (machine safety) must also be observed.
5. Unauthorized modifications to the PH300 exempt the manufacturer from any liability from resulting damage.
6. The relevant accident prevention regulations, as well as other generally recognized safety regulations, occupational health and structural regulations are to be observed.
7. Furthermore, the country-specific safety regulations also must be observed.

Explosion protection	Protection type
 	IP54

Product specific security regulations

General information

The PH300 fresh powder hopper unit is a constituent part of the equipment and is therefore integrated in the system's safety concept.

If it is to be used in a manner outside the scope of the safety concept, then corresponding measures must be taken.



NOTE:

For further information, see the more detailed Gema safety regulations!

Installation

Installation work to be done by the customer must be carried out according to local safety regulations.

Grounding

The fresh powder hopper grounding is to be checked at every start-up. The grounding connection is customer specific and is fitted on the booth base, on the cyclone and on the powder management center. The grounding of the workpieces and other plant units must also be checked.

Repairs

Repairs must be carried out by trained personnel only. Unauthorized conversions and modifications can lead to injuries and damage to the equipment. The Gema Switzerland GmbH guarantee would no longer be valid.



NOTE:

We point out that the customer himself is responsible for the safe operation of the equipment! Gema Switzerland GmbH is in no way responsible for any resulting damage.

By carrying out repairs, the fresh powder hopper must be disconnected from the mains, according to the local safety regulations!



NOTE:

Only original Gema spare parts should be used! The use of spare parts from other manufacturers will invalidate the Gema guarantee conditions!

About this manual

General information

This operating manual contains all important information which you require for the working with the PH300. It will safely guide you through the start-up process and give you references and tips for the optimal use of your new powder coating system.

Information about the function mode of the individual system components - booth, axis, gun control unit, powder gun or powder injector - should be referenced to their enclosed corresponding documents.



DANGER:

Working without operating instructions

Working without operating instructions or with individual pages from the operating instructions may result in damage to property and personal injury if relevant safety information is not observed.

- ▶ Before working with the device, organize the required documents and read the section "Safety regulations".
 - ▶ Work should only be carried out in accordance with the instructions of the relevant documents.
 - ▶ Always work with the complete original document.
-

Product description

Field of application

The PH 300 fresh powder hopper serves to continually supply powder to the coating plant.

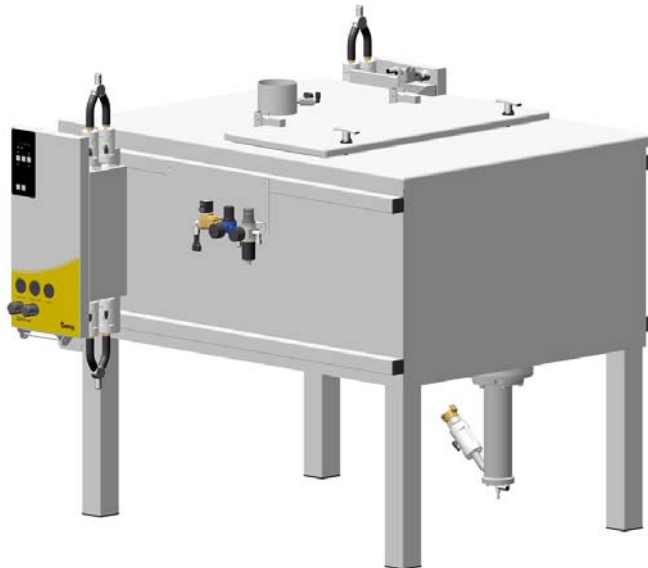

Utilization

The PH300 fresh powder hopper is suitable for use in single color plants. As a part of the process controlled coating plant, the fresh powder hopper is laid out for semi-automatic operation.

Reasonably foreseeable misuse

- Use of moist powder
- Insufficient fluidization
- Operation without the proper training

Technical data

Powder transport

PH300	
Conveying performance	6 kg/min.

Electrical data

PH300	
Connected load	1x230 V
Frequency	50/60 Hz
Protection type	IP54

Pneumatic data

PH300	
Input pressure	min. 6,5 / max. 10 bar
Compressed air consumption: - Fluidization - Conveying - Ventilation	approx. 40 Nm ³ /h approx. 11 Nm ³ /h approx. 2.5 Nm ³ /h
Water vapor content of compressed air	max. 1.3 g/m ³
Oil content of compressed air	max. 0.1 mg/m ³

Dimensions

PH300	
Base area (width x depth) (mm)	1230 x 1210
Overall height (mm)	1500
Weight (kg)	approx. 185 (with two PP06 pumps)

Processible powders

PH300	
Plastic powder	yes
Metallic powder	yes (bonded powders only)
Enamel powder	no

Sound pressure level

PH300	
Normal operation	< 55 dB(A)
Cleaning operation mode	< 67 dB(A)

The sound pressure level was measured while the unit was in operation; measurements were taken at the most frequent operator positions and at a height of 1.7 m from the ground.

The specified value is applicable only for the fresh powder hopper itself and does not take into account external noise sources or cleaning impulses.

The sound pressure level may vary, depending on the powder management center configuration and space constraints.

Rating plate

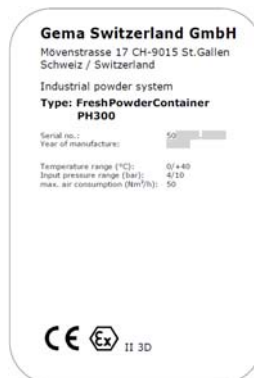

NOTE:

Fields with a gray background contain contract-specific data!

Design and function

General view

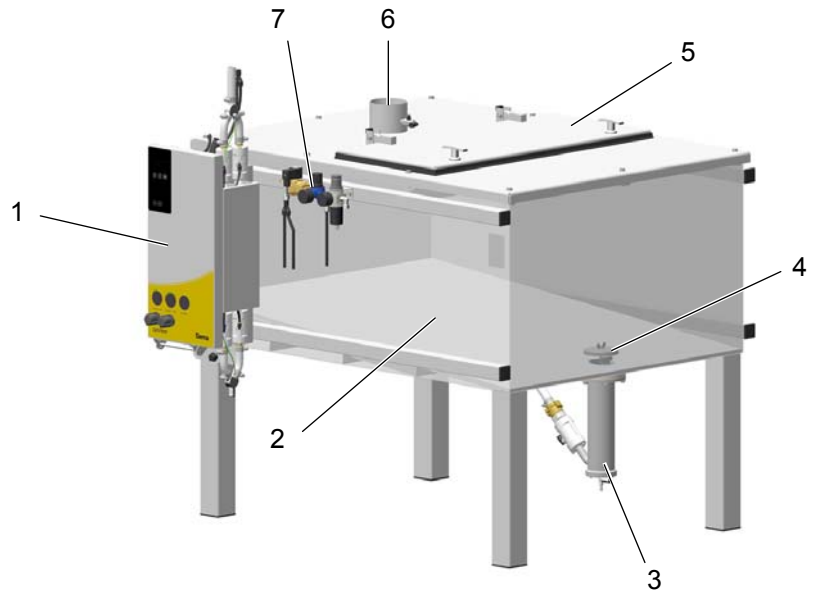

PH300 – structure

- | | | | |
|---|-------------------|---|----------------------|
| 1 | Powder pump | 5 | Powder filling cover |
| 2 | Fluidizing plate | 6 | Ventilation |
| 3 | Fluidized hopper | 7 | Pneumatic unit |
| 4 | Feed Control Hood | | |

Compressed air indicators

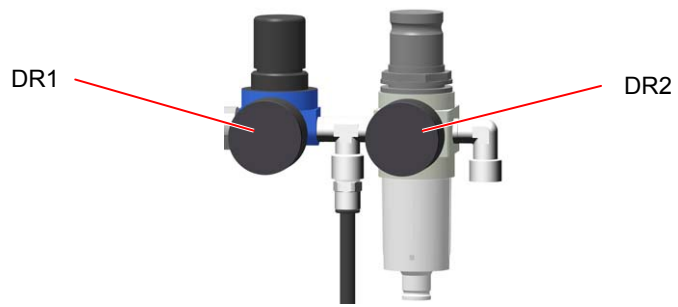

- DR1** Powder container fluidizing air
- DR2** Compressed air input

Feed Control Hood

The PH 300 Powder Hopper has a powder outlet in the fluidizing plate with a Dense Phase Conveyor. If the powder hopper is switched off directly after conveying, the still fluidized powder flows into the opening into the Dense Phase Conveyor. At the next 'restart' this can lead to clogging, so that the conveyor hose must be emptied first.

In order to prevent this problem, this feed control hood is fitted in the outlet opening. A ring slot around the outlet opening is created by the hood, so that powder can only flow slightly. The ring slot setting is, however, very much dependent on the flow characteristics of the powder and must, therefore, be set individually.

Because the Feed Control Hood is only a push fit, it can be removed for setting or cleaning.

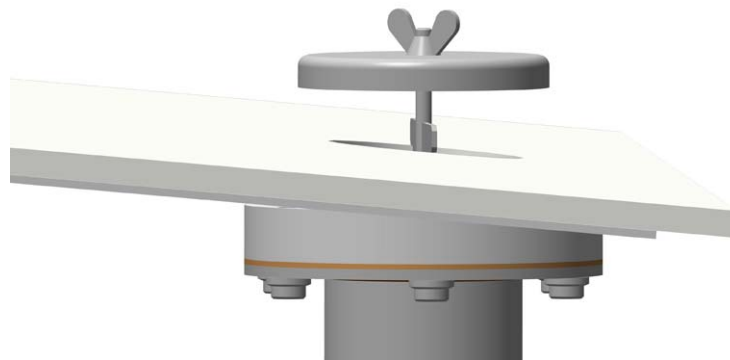

Principle of function

The PH 300 fresh powder hopper serves to continually supply powder to the coating plant. The hopper is fitted with a fluidizing plate, as well as with a Powder transport.

As soon as the coating plant is put into operation, the powder hopper is supplied with compressed air. The ventilation switches on to vent the hopper. The powder hopper is filled manually with powder, preferably from 25 kg powder bags. The large surface platform on the hopper for the powder bag, and the inclined filler plate serve the simple, and dust-free filling of the hoppers. Resulting dust is sucked up by the ventilation and can be fed back into the booth or the powder recovery. Because of additional dust development it is not recommended to refill during transport cycles.

If powder is now requested through the level sensor of the powder hopper, the fluidizing air, and the powder pump(s) are switched on. The powder is moved to the powder hopper, as long as the level sensor still requests powder.

The fresh powder hopper is not equipped with level monitoring, as the level sensor in the powder hopper releases a booth alarm as long as the correct powder level is not reached within the specified time.

Commissioning

Set-up and assembly



NOTE:

Installation work to be done by the customer must be carried out according to local safety regulations!



WARNING:

The fresh powder hopper must only be installed in locations with an ambient temperature of between +20 and +40 °C, i.e. never next to heat sources (such as an enameling furnace) or electromagnetic sources (such as a control cabinet).

- All hose connections should be as short as possible.
- The venting hose should be laid out without loops so that depositing, and clogging are prevented.
- Check the hose connections for a good seal, and firm seating
- Check the interlocking, so that the fresh powder hopper only works when the exhaust system is switched on.

Preparation for start-up

Compressed air supply



NOTE:

The compressed air must be free of oil and water!

The fresh powder hopper requires a connection to a sufficient dimensioned compressed air circuit.

In order to ensure a perfect operation, a pressure of **6 bar** must be adjusted with the main pressure regulator.



Compressed air supply

Grounding of the fresh powder hopper



DANGER:

The fresh powder hopper must be grounded according to the general, local safety regulations.

- ▶ The grounding of the fresh powder hopper must be checked regularly.

A corresponding connection point at the fresh powder hopper is reserved for the grounding.

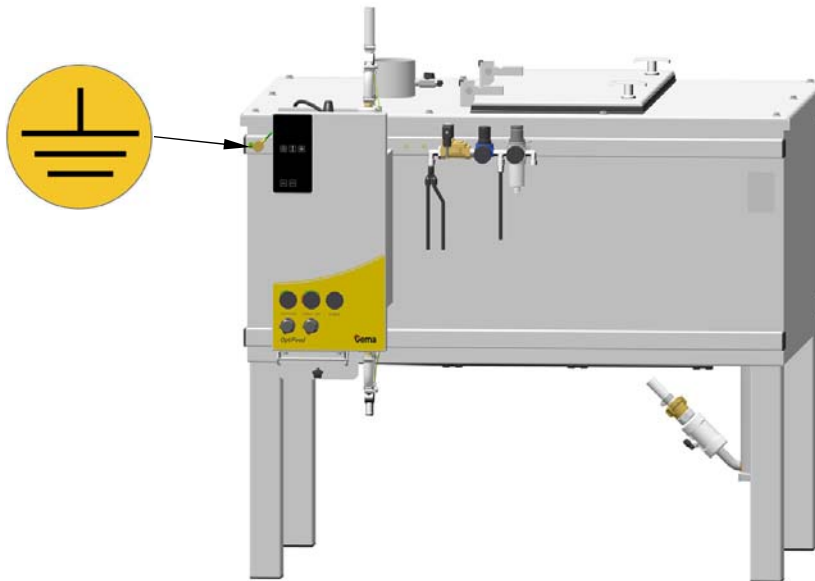

Grounding connection

Coating operation

Before switching on

Before switching on the fresh powder hopper, the following points must be observed:

- Observe the safety regulations
- Check the grounding of the fresh powder hopper, the booth and the other plant units and ensure it, if necessary
- Check the compressed air supply

Start up with the single control

The start-up takes place according the following steps:

1. Turn the main switch of the control unit to ON
2. Switch on the exhaust system
 - With this step the compressed air must also switch on and the pressure gauge on the control must display the following reference values:
 - Conveying air: approx. 1.5 bar
 - Valve pressure: approx. 2 bar
 - Fluidizing air: approx. 2-3 bar
 - Airmover: approx. 2.5-3.5 bar
3. Fill in powder
 - Because of additional dust development it is not recommended to refill the fresh powder hopper during a transport cycle.
4. The PH300 fresh powder hopper is ready for operation
 - When powder is requested through the level sensor in the powder hopper, a conveying cycle is released.
5. Switching off the exhaust system also automatically switches off the PH300 fresh powder hopper.

Start up with the main control

The start-up takes place according the following steps:

1. Turn the main switch of the booth control unit to ON
2. Switch on the control with key switch.
3. Switch on the plant
4. The exhaust air system is switched on
 - With this step the compressed air must also switch on and the pressure gauge on the booth control must display the following reference values:
 - Conveying air: approx. 1.5 bar
 - Valve pressure: approx. 2 bar
 - Fluidizing air: approx. 2-3 bar
 - Airmover: approx. 2.5-3.5 bar
5. Fill in powder
 - Because of additional dust development it is not recommended to refill the fresh powder hopper during a transport cycle.
6. The PH300 fresh powder hopper is ready for operation
7. Switching off the plant also automatically switches off the PH300 fresh powder hopper.

Cleaning



WARNING:

If no dust mask or one of an insufficient filter class is worn when cleaning the fresh powder hopper, then the dust that is stirred up from the coating powder can cause respiratory problems.

- ▶ The ventilation system must be turned on for all cleaning work.
 - ▶ A dust mask corresponding to filter class FFP2 or N95 at minimum must be worn during any cleaning work.
-



WARNING:

If no safety glasses are worn when cleaning the fresh powder hopper, then the dust that is stirred up from the coating powder can cause eye irritations.

- ▶ Safety glasses must be worn during any cleaning work!
-

Setting values

Setting values are reference values, and must be set according to operational experience.

Compressed air

PH300	
Conveying air	1,5 bar
Pinch valve pressure	2 bar (must not be increased because a higher pressure will lead to damage of the sleeves)
Airmover	2.5-3.5 bar
Fluidizing air	2-3 bar

Fault localization

General information

The causes of these errors must be eliminated, before further procedures are carried out.

Always check the following points first when there are faults in the fresh powder supply:

- Is Mains voltage present?
- Is compressed air present (min. 4 bar)?

Fault	Error/solution
Powder discharges from the fresh powder hopper	<ul style="list-style-type: none"> - Too little air pressure at the Airmover - Venting hose clogged - Heavy sintering in the Airmover
conveying performance too low	<ul style="list-style-type: none"> - Fluidizing in the fresh powder hopper not switched on - Too little fluidizing air - Powder pump defect
Conveying runs continuously	<ul style="list-style-type: none"> - Control incorrectly set

Maintenance

Monitoring during operation

- Check the compressed air: Displays on the pressure gauges remain the same.

Daily maintenance

- Check the compressed air: Displays on the pressure gauges correspond exactly with the values set
- Transport hose: Check for sintering on the inside
- Transport hose connection: Check for sintering on the inside
- Airmover: Check for sintering
- Venting hose: Blow out, and check for sintering

Additional monthly maintenance work

- Intermediate hopper
- Check for sintering on the inside
- Check the fluidizing plate

Decommissioning, storage

Introduction

Safety rules

Suitable equipment (e.g. a crane) must be used when moving parts that are sometimes bulky and heavy.

Components being disassembled must be adequately secured before they are detached.

Requirements on personnel carrying out the work

Use only technical personnel who are trained in operating the respective equipment (e.g. a crane).

If there are any uncertainties, please contact Gema.

Storage conditions

Storage duration

If the physical conditions for metal parts and electronics are maintained, the unit can be stored indefinitely. On the other hand, the installed elastomeric components (pinch valve collars, O-ring seals, etc.) can become brittle over time and crack when put under repeated loads.

Space requirements

The space requirements correspond to the size of the fresh powder hopper.

The load-bearing capacity of the floor should be at least 200 kg/m².

There are no special requirements concerning distance to neighboring equipment.

Physical requirements

Storage must be inside a dry building at a temperature between +5 and +40 °C. Preferably in a cool, dry and dark space.

Do not expose to direct sunlight.

Hazard notes

There is no danger to personnel or the environment if the unit is stored properly.

Shut-down

Decommissioning

Before starting any kind of work, the fresh powder hopper must be disconnected from the compressed air supply.

- Relieve pneumatic pressure on the system
- Unplug the power cable
- Unplug the ground cable
- Empty the powder container (see "Cleaning")

Cleaning

The complete fresh powder hopper is to be cleaned according to the instructions in the operating manual.

Disassembly/attachment of transport safety devices

- Fasten the powder container cover

Packing

It is recommended that the fresh powder hopper is placed on a dimensionally stable, adequately large palette using a forklift truck with long forks. To prevent damage to the components, collisions with other parts must be prevented.

Identification

Apply the label "Protect from dampness and moisture" on the product and the packaging.

Maintenance during storage

Maintenance schedule

No maintenance schedule is necessary.

Maintenance works

During long-term storage, periodically perform a visual check.

Return to service

Commissioning following storage

Following storage of more than 3 years, the rubber components must be checked and replaced if necessary.

Packing, transport

Introduction

This chapter describes special precautions that must be taken during internal transport of the product if:

- the customer himself must pack, transport and ship the product, such as to have renovations or service work carried out by the manufacturer

or

- the product must be shipped for disposal (recycling).

Safety rules

Suitable equipment (e.g. a crane) must be used when moving parts that are sometimes bulky and heavy.

Components being disassembled must be adequately secured before they are detached.

Requirements on personnel carrying out the work

Use only technical personnel who are trained in operating the respective equipment (e.g. a crane).

If there are any uncertainties, please contact Gema.

Packing material

A suitably stable pallet must be used.

Transport

Data concerning goods to be transported

- The space requirements correspond to the size of the components plus the packaging
- Weight see "Technical Data"
- Points of attachment, see "Mode of transportation"

Mode of transportation

For short distances/shifts of position within the same room, parts for the booth must be transported using a forklift truck with long forks or a crane.

Transport the unit only in the position according to its intended use.

Loading, transferring the load, unloading

Suitable lifting equipment is to be used for all procedures.

Spare parts list

Ordering spare parts

When ordering spare parts for powder coating equipment, please indicate the following specifications:

- Type and serial number of your powder coating equipment
- Order number, quantity and description of each spare part

Example:

- **Type** PH300
Serial number 1234 5678
- Order no. 203 386, 1 piece, Clamp – Ø 18/15 mm

When ordering cable or hose material, the required length must also be given. The spare part numbers of this bulk stock is always marked with an *.

Wearing parts are always marked with a #.

All dimensions of plastic hoses are specified with the external and internal diameter:

Example:

Ø 8/6 mm, 8 mm outside diameter (o/d) / 6 mm inside diameter (i/d)



WARNING!

Only original Gema spare parts should be used, because the explosion protection will also be preserved that way. The use of spare parts from other manufacturers will invalidate the Gema guarantee conditions!

PH300 Fresh powder hopper

1 OptiFeed PP06 Powder pump – see corresponding operating manual

2 Pneumatic unit – see corresponding spare parts list

3 Fluidized hopper – see corresponding spare parts list

4 Fluidizing plate

365 009#

Wearing part

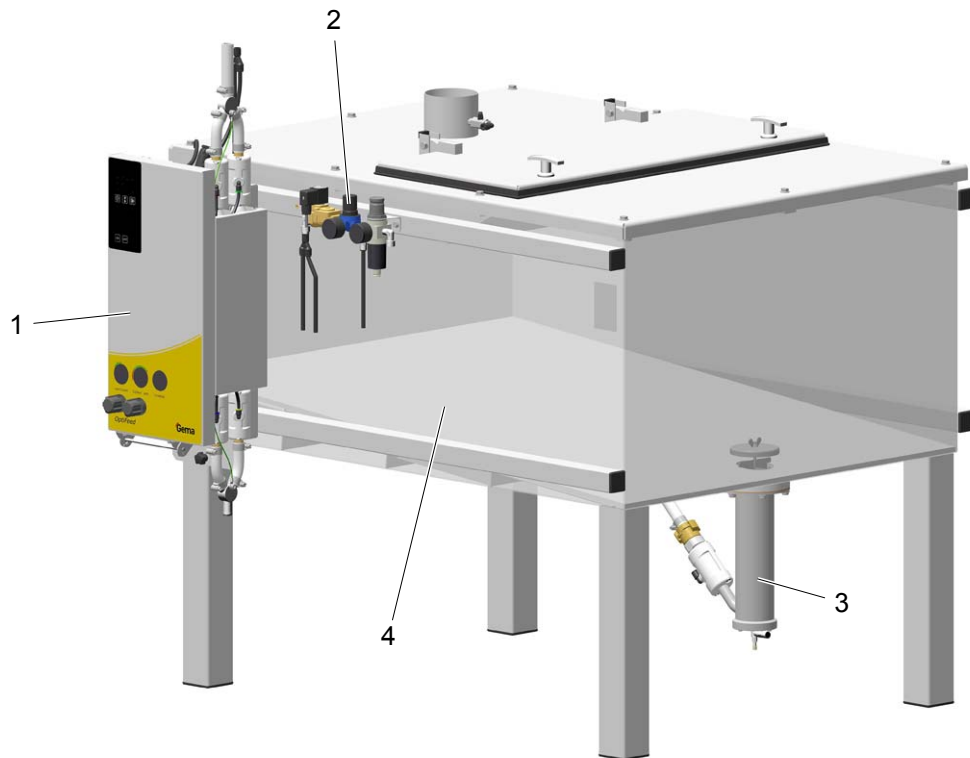

PH300 Fresh powder hopper

Pneumatic unit – PH300

1	Y-connection fitting – 1/4"-Ø 8 mm	260 215
2	Solenoid valve – 1/2", NW13.5 mm, without coil	1005 120
3	Valve coil – 24 VDC-Ex	1005 119
4	Pressure gauge – 0-4 bar, 1/8"	258 997
5	Pressure regulator – 0-4 bar, 1/4"	240 141
6	Pressure gauge – 0-10 bar, 1/8"	259 179
7	R/F unit – 0-8 bar, 1/4", incl. pos. 8 and 9	1008 236
8	Filter cartridge – 20 µm	1008 239#
9	Condensate container with drain valve	1008 238

Wearing part

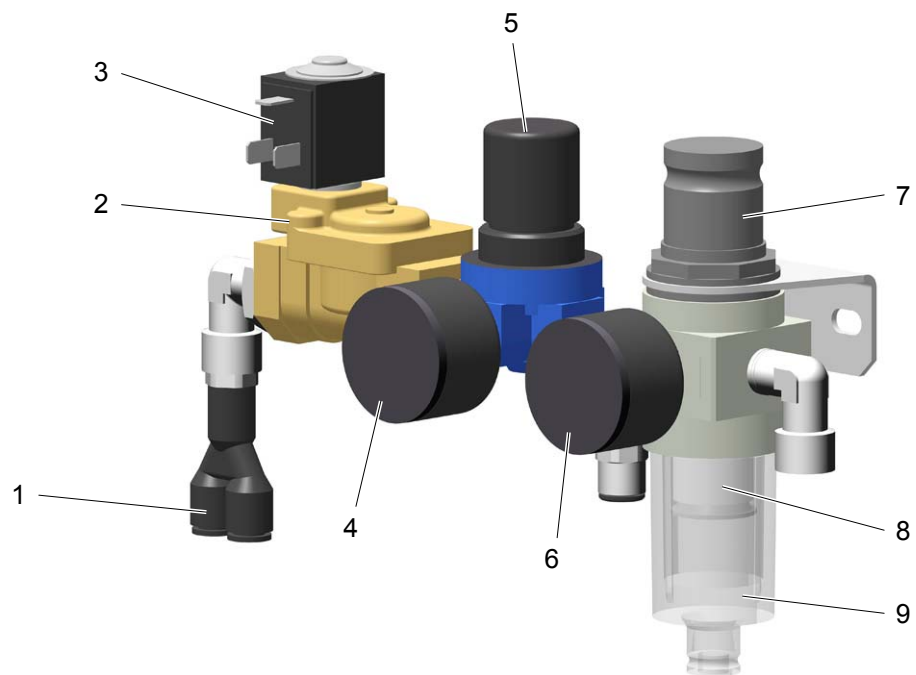

PH300 Pneumatic unit

Fluidized hopper – PH300

1	Geka coupling – 1"	1000 854
2	Connecting piece	1005 503
3	Pinch valve DN15 – complete, incl. pos. 3.1	1006 255
3.1	Pinch valve sleeve DN15 – not shown	1006 256#
4	Elbow joint – 1/4"-Ø 8 mm	254 029
5	Cap screw – M4x12 mm	216 798
6	Throttle valve – 1/8"-1/8"	1002 127
7	Screw-in nipple – 1/8"-Ø 8 mm	240 087
8	Base piece	1006 655
9	O-ring – Ø 64x3 mm, NBR70	255 335
10	Gasket	395 439
11	GEKA coupling with grommet – Ø 16 mm	1003 872
12	Hose clamp – 17-25 mm	223 085
13	Powder hose – Ø 16/23 mm, anti-static	1010 040*#

Wearing part

* Please indicate length

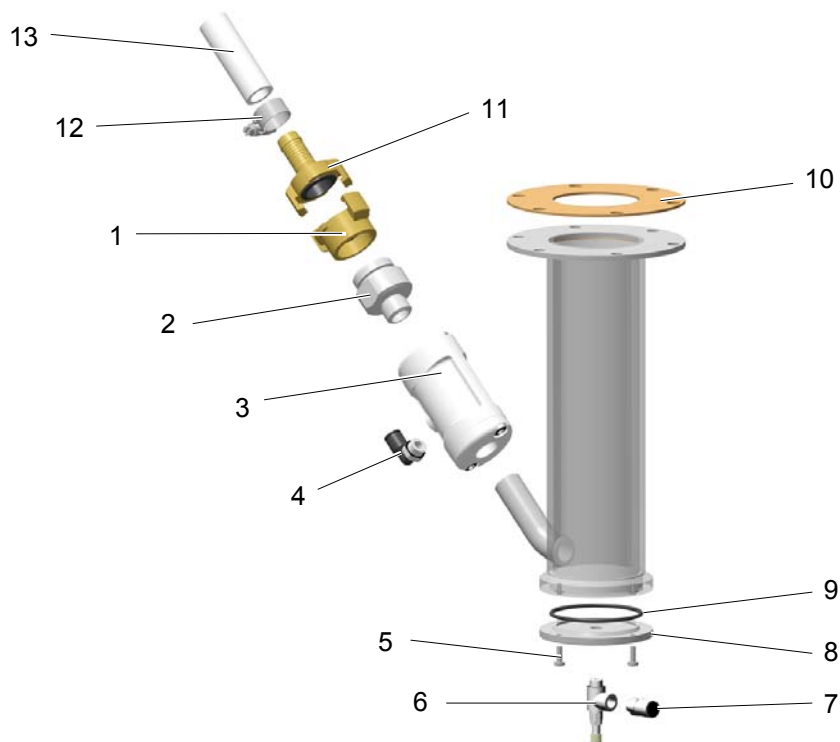

Fluidized hopper – PH300

